

ON KHOVANOV AND KNOT INSTANTON HOMOLOGY

YU LEON LIU

In this minor thesis we examine the relationship between Khovanov homology [1] and knot instanton homology, more specifically the one defined in [3]. While both are homology theory for knots, they are defined in completely different fashions: Khovanov homology is algebraic, uses link diagrams, and categorifies the Kauffman brackets. On the other hand, knot instanton homology belongs to a family of Floer homology theories, which do Morse theory on the infinite dimensional space of instantons and requires difficult analytic results. The main theorem is the following ¹:

Theorem 0.1. *Let L be a link in \mathbb{R}^3 . There is a spectral sequence, whose E_2 page is the Khovanov homology ² $Kh(L)$ of the link L , converging to the knot instanton homology $I^\sharp(L)$.*

In this notes, we will define both Khovanov homology and knot instanton homology, and cover the proof of this theorem (following [3]).

Remark 0.2. Using this spectral sequence, Kronheimer and Mrowka in [3] was able to show that Khovanov homology is an unknot detector: a knot K is the unknot iff the reduced Khovanov homology $\text{Khr}(K)$ is \mathbb{Z} . Let us sketch the argument: with a bit more work, one can show that there is a spectral sequence whose E_2 page is the reduced Khovanov homology $\text{Khr}(K)$, converging to the reduced instanton homology $I^\sharp(K)$, a variant of $I^\natural(K)$, defined in Section 2.4. Furthermore, using the excision property of $I^\natural(K)$, one can show $I^\sharp(K)$ is isomorphic to the sutured Floer homology of the knot complement, whose rank is a known unknot detector [2]. Namely, K is an unknot iff $I^\natural(K)$ is \mathbb{Z} . Since reduced Khovanov homology is the E_2 page of the spectral sequence, its rank has to be larger than the rank of $I^\natural(K)$, therefore $\text{Khr}(K)$ being rank one implies that K is the unknot.

Outline: In Section 1 we quickly review the construction of Khovanov homology, following [1]. In Section 2 we develop the necessary background on singular instanton and the moduli space of ASD connections on them. In Section 3 we define various knot instanton homologies using the machinery in the previous section. In Section 4 we prove a Skein long exact sequence result, which is the building block of the spectral sequence. In Section 5 we generalize the knot instanton construction which incorporates the cube of resolution, and prove Theorem 5.18, which is a generalization of the Skein long exact sequence result. In Section 6 we show that the E_2 of the spectral sequence is the Khovanov homology.

Acknowledgement: I would like to graciously thank Professor Peter Kronheimer for supervising my minor thesis.

¹This is not the first paper constructing a spectral sequence from Khovanov homology to objects in Floer homology, see [4].

²Note that we really construct the Khovanov homology of the mirror link, as we swap the notion of 0 and 1 resolutions to be more consistent with later sections.

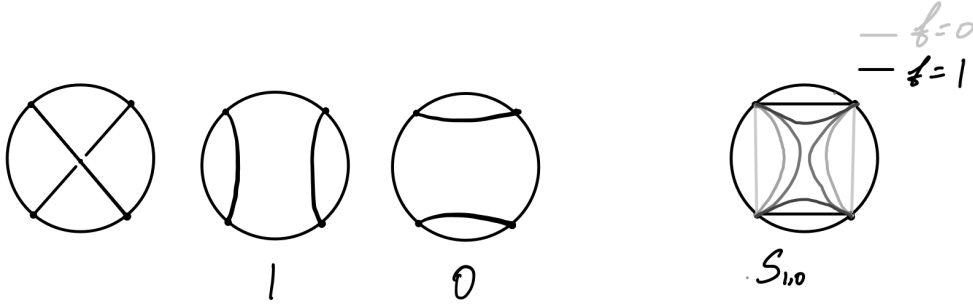

FIGURE 1. On the left we see a local crossing and its 1 and 0 resolutions. On the right we see the bordism from the 1 resolution to the 0 resolution.

1. KHOVANOV HOMOLOGY AND THE CUBE OF RESOLUTIONS

1.1. Cube of resolutions. Let L' be a link diagram, that is, a 2D projection of a link, see Figure 1. We can “smooth” the crossing by locally modifying it. Moreover, there is a natural bordism $S_{1,0}$ from the 1 resolution to the 0 resolution.³

Let J be the set of crossings, then for each element $v \in [0, 1]^J$, we have a disjoint union of circles in the plane L'_v (a link diagram with no crossing), by replacing the crossing by the v_j -th resolution at crossing j . Furthermore, given two elements v, v' with $v'_j \geq v_j$ for every j , then there is a canonical bordism $S_{v,v'}$ from L'_v to $L'_{v'}$: away from the crossing the bordism is the trivial bordism, and at the j crossing it is the bordism $S_{1,0}$ (see Figure 1) when $v'_j > v_j$ and the trivial bordism when $v'_j = v_j$. We call this the cube of resolution. See Figure 2 for an example.

1.2. Khovanov homology. Using the cube of resolution, we are going to construct a chain complex of graded abelian groups $\text{Kh}(L')$ to each link diagram L' , following [1].

To do that, we first have to introduce V :

Definition 1.1. As a graded abelian group, $V = \mathbb{Z}[1] \oplus \mathbb{Z}[x]$, where 1 lives in degree 1 and x lives in degree -1 . Furthermore, we have a multiplication $\mu : V \otimes V \rightarrow V$:

$$(1.2) \quad \mu : 1 \otimes 1 \mapsto 1, 1 \otimes x, x \otimes 1 \mapsto x, x \otimes x \mapsto 0.$$

and comultiplication $\Delta : V \rightarrow V \otimes V$:

$$(1.3) \quad \Delta : 1 \mapsto 1 \otimes x + x \otimes 1, x \mapsto x \otimes x.$$

Remark 1.4. (V, μ, Δ) extends to a commutative Frobenius algebra, see [1] for detail.

Now we can construct the Khovanov chain complex:

Construction 1.5. Let L' be a link diagram and J the set of crossings. For each $v \in [0, 1]^J$, if L'_v has n components we assign the abelian group $C\text{Kh}(L'_v) := V^{\otimes n}$. Furthermore, let $v' >_1 v$ differ by a single crossing, we assign a map $f_{v,v'} : C\text{Kh}(v) \rightarrow C\text{Kh}(v')$ by the following rule:

- (1) $f_{v,v'}$ is identity away from the V 's labelled by the circle components in the crossing.
- (2) If two circle components merge into one, then we assign $\mu : V^{\otimes 2} \rightarrow V$. See left half of Figure 3.

³Our numbering of the resolution is reverse of Khovanov's, in particular, our 1 resolution is his 0 resolution in [1]

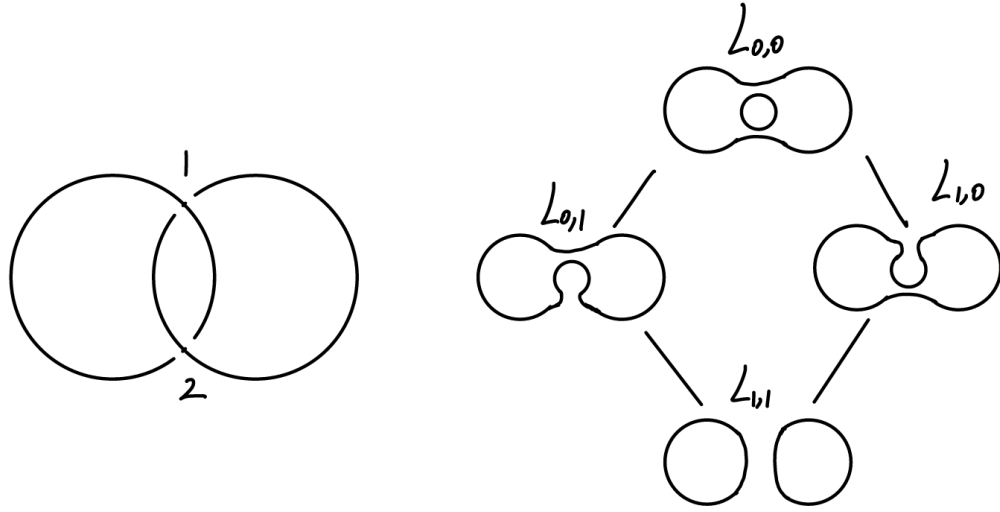

FIGURE 2. The cube of resolution for the Hopf link H .

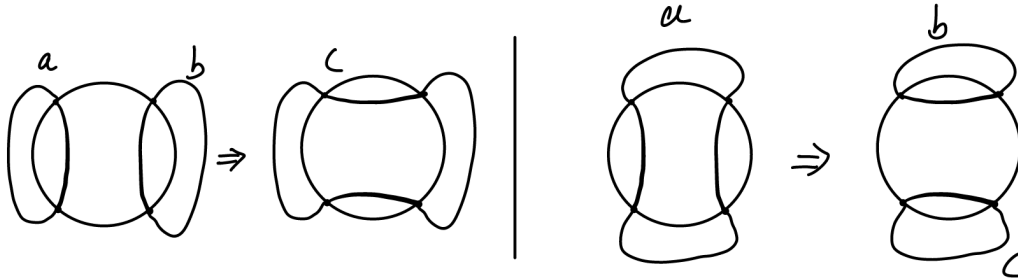

FIGURE 3. The two different scenarios for $S_{1,0}$.

(3) If one circle splits into two, then we assign $\Delta : V \rightarrow V^{\otimes 2}$. See right half of Figure 3.

Now we define the Khovanov chain complex as follows: The d -th (cohomological) graded abelian group is $\oplus_{v_d} \text{CKh}(L'_{v_d})[d]$, where v_d runs over v with d many 1 resolutions. The differential

$$(1.6) \quad \partial : \oplus_{v_d} \text{CKh}(v_d) \rightarrow \oplus_{v'_{d+1}} \text{CKh}(v'_{d+1})$$

is defined by $\sum_{d,d'} (-1)^{\sigma_{v_d, v'_{d+1}}} f_{v_d, v'_{d+1}}$, where $\sigma_{v_d, v'_{d+1}}$ are signs that we will not specify. See [1] for details.

Khovanov in [1] proved that its homology is a link invariant ⁴:

⁴Again we are really defining the Khoavnov homology of the mirror link \bar{L} .

Theorem 1.7 (Khovanov). *The doubly graded cohomology groups $H^*(\text{Kh}([L']))$ is independent of the link diagram L' .*

From now on, we will denote the Khovanov homology L of a link as $\text{Kh}(L)$.

2. BACKGROUND ON INSTANTON HOMOLOGY

2.1. How to do Floer homology. Let us quickly review the basic idea of Floer homotopy theory. The starting point is the relationship between the Chern-Simons functional and the ASD equations. Let Y be a three manifold and P a principle $SU(2)$ bundle on Y . We have the Chern-Simons functional $CS(A) = A \wedge dA + \frac{2}{3}[A, A]$ on the space of connections. The critical points are the flat connections.

On the other hand, on a four-manifold (possibly with boundary) X and a principle G bundle P on X , fix a Riemannian metric g on X , one can define the anti-self dual (ASD) equation:

$$(2.1) \quad F_A^+ = 0$$

where F_A is the curvature of A and $(-)^+$ is the projection to the self-dual part of the curvature.

We have the following:

Proposition 2.2. *Consider the product four manifold $\mathbb{R} \times Y$. A connection A on Y gives rise to a product connection $A + dt$ on $\mathbb{R} \times Y$. Then A is a flat connection (a critical point of the CS functional) iff $A + dt$ solves the ASD equation.*

This means that we can do Morse theory on the space of connections: The critical points are the flat connections and the gradient flow equation is the ASD equation. We will adopt this approach to our setting, which involves instantons with singularity around links and link bordisms.

2.2. Singular instantons. First let us explain the motivation: fixing an oriented four manifold X with an embedded surface Σ . We are interested in instantons on X with singularities around Σ , on principle $G = SO(3) = PSU(2)$ bundles that doesn't extend over Σ .

It turns out the ones that we care about will give rise to an extension over a 2-fold cover $\pi : \Sigma_\Delta \rightarrow \Sigma$. Now let us give an model example:

Example 2.3. Consider a flat G connection on $B^4 \setminus B^2$ with holonomy around the linking circle being order 2 ⁵ The eigenspaces of the holonomy decomposes the fundamental \mathbb{R}^3 bundle as $\xi \oplus Q$, where $\xi \simeq \mathbb{R}$ is the trivial rank-1 bundle and Q is the rank 2 bundle, with eigenvalue -1 . Now we can construct a new connection:

$$(2.4) \quad A_0 = A_1 - \frac{1}{4} \mathbf{i} d\theta$$

where $d\theta$ is an angular coordinate normal to B^2 , and \mathbf{i} is a section of the adjoint representation that kills ξ and squares -1 on Q (so a 90 degree rotation on Q). Therefore A_0 has trivial holonomy and the bundle extends over B^2 .

However, at each point, there is two choices of $\mathbf{i} d\theta$. Therefore globally, the family of choices forms a double cover Σ_Δ over Σ .

To package this together, we can consider principle G bundles on the non-Hausdorff space X_Δ , which is X glued with Σ_Δ along Σ . This is a space with a map to X , with single fibers over $X \setminus \Sigma$ and double fibers over Σ . Now we will develop the language to set this up.

⁵So a 180 degree rotation around some plane.

Definition 2.5. Let $\Sigma_\Delta \rightarrow \Sigma$ be a double cover, aka a principal $\mathbb{Z}/2$ bundle. Let μ be a tubular neighborhood of Σ in X and $\tilde{\mu}_\Delta \rightarrow \mu$ be the corresponding double cover. The non-Hausdorff space X_Δ is the identification of $X \setminus \Sigma$ and $\tilde{\mu}_\Delta$, where each point in $x \in \tilde{\mu}_\Delta \setminus \Sigma$ is identified with its image in $X \setminus \Sigma$.

Let $\mu_\Delta \subset X_\Delta$ be the image of $\tilde{\mu}_\Delta$.

Remark 2.6. We can think of X_Δ as the formal stacky pushout:

$$(2.7) \quad \begin{array}{ccc} \tilde{\mu}_\Delta \setminus \Sigma & \longrightarrow & X \setminus \Sigma \\ \downarrow & & \\ \tilde{\mu}_\Delta & & \end{array}$$

Similarly for μ_Δ :

$$(2.8) \quad \begin{array}{ccc} \tilde{\mu}_\Delta \setminus \Sigma & \longrightarrow & \mu \setminus \Sigma \\ \downarrow & & \\ \tilde{\mu}_\Delta & & \end{array}$$

Definition 2.9. A principle G bundle $P_\Delta \rightarrow X_\Delta$ is the data of:

- (1) A G bundle on $\tilde{\mu}_\Delta$ and $X \setminus \Sigma$.
- (2) A bundle isomorphism on their pullback to $\tilde{\mu}_\Delta \setminus \Sigma$.

Similarly for μ_Δ .

Lastly, we want a $O(2)$ reduction of $P_\Delta|_{\mu_\Delta}$ in a special form: given a rank 2 bundle $\tilde{Q} \rightarrow \Sigma_\Delta$, such that the orientation bundle identified with that of Σ_Δ : $o(\tilde{Q}) \simeq o(\Sigma_\Delta)$. Note that $o(\Sigma_\Delta)$ is pulled back from Σ and is therefore invariant under deck transforms. Now to make a bundle over the quotient μ_Δ , we must give an identification $Q|_{\mu_\Delta} \simeq \tau^*Q|_{\mu_\Delta}$.

Let N_{Σ_Δ} be the normal bundle of Σ pulled back to Σ_Δ . Note that it has a canonical section s_1 when pulled back to $\tilde{\mu}_\Delta$. Consider an orientation preserving isometry

$$(2.10) \quad \rho : N_{\Sigma_\Delta} \rightarrow \text{Hom}^-(\tau^*(\tilde{Q}), \tilde{Q})$$

where Hom^- means orientation reversing maps. In addition, ρ has to satisfy the constraint $\rho(v)\rho(\tau(v)) = 1$ for any unit vector $v \in N_{\Sigma_\Delta}$. In particular, $\rho(s_1)$ gives an gluing of Q and τ^*Q on $\tilde{\mu}_\Delta \setminus \Sigma$. Using this, we can define singular bundle data on (X, Σ) :

Definition 2.11. A singular bundle data is the following:

- (1) A double cover $\Sigma_\Delta \rightarrow \Sigma$.
- (2) A principle G bundle $P_\Delta \rightarrow X_\Delta$.
- (3) A rank 2 bundle $\tilde{Q} \rightarrow \Sigma_\Delta$ whose orientation bundle is identified with $o(\Sigma_\Delta)$, the orientation bundle for Σ_Δ .
- (4) An orientation-preserving isometry $\rho : N_{\Sigma_\Delta} \rightarrow \text{Hom}^-(\tau^*(\tilde{Q}), \tilde{Q})$, which defines a quotient bundle Q_Δ on μ_Δ by above.
- (5) A $O(2)$ reduction of $P_\Delta|_{\mu_\Delta}$ to Q_Δ .

Remark 2.12. In this case, Σ_Δ is determined by P , by the argument in Example 2.3 above.

2.3. Topological classification of singular bundle data. We are interested in classifying singular bundles on X_Δ . To start, we replace the non-Hausdorff space by a nicer space X_Δ^h with the same homotopy type:

Definition 2.13. Let $\partial(\tilde{\mu}_\Delta)$ be the boundary of $\tilde{\mu}_\Delta$. X_Δ^h is the pushout

$$(2.14) \quad \begin{array}{ccc} \partial(\tilde{\mu}_\Delta) & \longrightarrow & X \setminus \text{int}(\mu) \\ \downarrow & & \\ \tilde{\mu}_\Delta & & \end{array}$$

Therefore we are only identifying away from a disk bundle.

We get an induced map $\pi : X_\Delta^h \rightarrow X$, with single fibers away from $\text{int} \mu$ and the inverse image of μ is a 2-sphere bundle D over Σ . There is an involution $t : X_\Delta^h \rightarrow X_\Delta^h$ over X that is an orientation-reversing map for each 2-sphere.

Let us describe its various homology and cohomology classes:

Lemma 2.15. $H_4(X_\Delta^h; \mathbb{Z})$ has rank $1 + s$ where s is the number of components on Σ where Δ is trivial. Given a trivialization of Δ , the free generators are the fundamental classes of 2-sphere bundle D , and an additional integer class $[X_+]$ coming from a section $X \rightarrow X_\Delta^h$. If Δ non-trivial, free generators are the fundamental class of the orientable component, and $2[X_\Delta]$. $2[X_\Delta]$ is defined follows: away from the disk bundle it is pulled back from $X \setminus \Sigma$, inside the disk bundle we pick half a sphere for each component of Σ .

Lemma 2.16. Let a be the components of Σ where Δ is non-trivial, then the torsion subgroup of $H^4(X_\Delta^h; [\mathbb{Z}])$ is isomorphic to $(\mathbb{Z}/2)^{a-1}$ for $a \geq 2$, zero otherwise. Given x_1, \dots, x_a in different components of D , ξ_i be the image in $H^4(X_\Delta^h)$ of a generator of $H^4(X_\Delta^h, X_\Delta^h - x_i) \simeq \mathbb{Z}$ with

$$\langle \xi_i, [X_\Delta] \rangle = 1$$

. Then the generators are $\xi_i - \xi_{i+1}$.

Lastly, this follows from the Mayer-Vietoris:

Lemma 2.17. The group $H^2(X_\Delta^h; \mathbb{Z}/2)$ lies in an exact sequence:

$$(2.18) \quad 0 \rightarrow H^2(X; \mathbb{Z}/2) \rightarrow H^2(X_\Delta^h; \mathbb{Z}/2) \xrightarrow{e} (\mathbb{Z}/2)^N \rightarrow H_1(X)$$

where N is the number of components of Σ , e is restriction to the fibers $S_i^2 \subset D$, one for each component of Σ .

Now to classify $SO(3)$ bundles on a topological space Z : first P has a $w_2(P) \in H^2(Z; \mathbb{Z}/2)$. Furthermore, the isomorphism class of bundles with given w_2 is acted transitively by $H^4(Z; \mathbb{Z})$ by inserting instantons. The action might not be free when X has 2-torsion, the kernel is subgroup $T^4(Z; w_2) = \{\beta(x) \cup \beta(x) + \beta(x \cup w_2) | x \in H^1(Z; \mathbb{Z}/2)\}$ where β is the Bockstein $H^i(Z; \mathbb{Z}/2) \rightarrow H^{i+1}(Z; \mathbb{Z})$.

Note that singular bundle data implies that $w_2(P_\Delta)$ is non-zero for every 2-sphere fiber in D .

Proposition 2.19. The possible w_2 for singular bundle data lies in a single coset of $H^2(X; \mathbb{Z}/2)$ in $H^2(X_\Delta, \mathbb{Z}/2)$. Fix a w_2 in such coset. $H^4(X_\Delta, \mathbb{Z})$ acts transitively on the isomorphism class of P_Δ with fix w_2 bundle in the following way: given element $\lambda \in H^4(X_\Delta, \mathbb{Z})$, suppose it is the characteristic class of a single oriented 4-simplex σ ,

- (1) If σ lies in $X \setminus \mu \subset X_\Delta^h$, which we call it adding an instanton.
- (2) If σ lies in an orientable component of D , furthermore, it lies in the distinguish copy of μ chosen in $[X_\Delta]$, we call it adding an anti-monopole.
- (3) If it lies on the other copy or D is not orientable, call it adding a monopole.

Furthermore, from the description of $H^4(X_\Delta^h; \mathbb{Z})$, we have the following rules:

- (1) *adding a monopole and anti-monopole to an orientable component is same as adding an instanton.*
- (2) *Adding two monopoles in an non-orientable component is the same as adding an instanton.*
- (3) *For any $x \in H^1(X; \mathbb{Z}/2)$, let n be the number of components where $w_1(\Delta) \cup x$ is non-zero, then adding n monopoles in those components is equivalent to adding $n/2$ instantons. Note n is necessarily even.*

2.4. Singular instantons on knots and Chern-Simons functional. Fix a closed oriented connected three manifold Y with a link $L \subset Y$. Once again we fix $G = SO(3)$, although much of this generalizes.

Definition 2.20. A singular bundle data is the following:

- (1) A double cover $L_\Delta \rightarrow L$.
- (2) A G bundle P_Δ on the non-Hausdorff sapce Y_Δ .
- (3) A reduction of the structure group to $O(2)$ in a neighborhood L_Δ of L , in the standard form describe inSection 2.2.

We pick an orbifold riemannian metric \tilde{g} on Y with orbifold angle π around L . Using this we have the affine space of connections $\mathcal{C}(Y, L, P)$ ⁶ and $\mathcal{G}(Y, L, P)$ the gauge transforms. Let $\mathcal{B}(Y, L, P) = \mathcal{C}(Y, L, P)/\mathcal{G}(Y, L, P)$ We also have an inner product:

$$(2.21) \quad \langle b, b' \rangle = \int_Y -tr(*b \wedge b')$$

where tr is the killing form and Hodge star is from \tilde{g} . Using this, we can define the Chern-Simons function CS via

$$(2.22) \quad (dCS)_\mathcal{B} = (*F)_\mathcal{B}$$

The critical points of CS on \mathcal{B} are flat connections mod gauge equivalence, which we denote as \mathfrak{C} .

Now we have to ensure we don't have reducible connections. Let's briefly recall reducible connections:

Definition 2.23. A connection A is reducible if its fixed point subgroup $\mathcal{G}_A \subset \mathcal{G}$ under gauge transform is larger than the center⁷. Equivalently, the holonomy group is a proper subgroup of G .

The notion of non-integral condition ensures this:

Definition 2.24. Given (Y, L, P) . An embedded closed oriented surface Σ is a non-integral surface is either

- (1) Σ is disjoint from L and $w_2(P)$ is non-zero on Σ , or
- (2) Σ is transverse to L and $L \cap \Sigma$ is odd.

We say P satisfies the non-integral condition if there is a non-integral surface Σ in Y .

Proposition 2.25. *If (P, Y, L) satisfies the non-integral condition, then the CS function has no reducible critical points. Furthermore, if Δ is non-trivial on any component, then $\mathcal{C}(Y, L, P)$ has no reducible connections at all.*

2.5. Moduli space of singular instantons. Now we move on to the moduli space of ASD connections on bordisms. Fix bordism (W, S) from (Y_1, L_1) to (Y_0, L_0) together with a singular instanton bundle P on W . Now we extend (W, S) to a cylindrical bordism by gluing $(-\infty, 0] \times Y_1$ and $[0, \infty) \times Y_2$ at the ends. Let P_1, P_0 denote the restriction to Y_1 and Y_0 .

⁶Define this rigorously involves Sobolev spaces

⁷Note that constant gauge transform by the centralizer stabilizes all connections

Furthermore, we choose an orbifold metric \tilde{g} (with singularity along S) such that the ends are given by $dt^2 + \tilde{g}_1$ and $dt^2 + \tilde{g}_0$ respectively, where \tilde{g}_1 and \tilde{g}_0 are orbifold metrics on Y_1 and Y_0 .

Now fix critical points $\beta_1 \in \mathfrak{C}_1$, $\beta_0 \in \mathfrak{C}_0$. We consider all orbifold connections on P ⁸ such restricts to β_1 and β_0 at infinities. Let $M(\beta_1, \beta_0)$ be the solution to the ASD equation $F_A^+ = 0$ on W .

At this point, we need to add perturbation to make sure the critical points are discrete and the moduli spaces are smooth manifold, which boils down to the surjectivity (regularity) of the Fredholm maps on tangent spaces. We simply quote the statement here:

Proposition 2.26. *Assume non-integral condition. There is a perturbation of CS functional, and compatible perturbation of the ASD equation, such that*

- (1) *All the critical points of the perturbed CS functional are irreducible and non-degenerate in the direction transverse to the gauge orbits, thus \mathfrak{C} is discrete and finite.*
- (2) *For any critical points β_1, β_0 in $\mathfrak{C}_1, \mathfrak{C}_2$, the moduli space of solutions of the perturbed ASD connections $M(\beta_1, \beta_0)$ is regular, that is, a (possibly non-compact) manifold.*

From now on, we will always use singular bundles with non-integral condition, and choose a perturbation with discrete critical points and regular moduli spaces.

2.6. Broken metric and compactification of the moduli space. Lastly, we need to compactify the moduli space. In particular, we want to understand the limits of 1 dimensional families of instantons.

To do this, we consider a family of metrics on bordisms (W, S, P) ⁹ over parameter space G . In this case, we have a moduli space $M(W, S, P) \rightarrow G$, consisting of pairs $([A], g)$ where A solves the ASD equation with metric g .

Once again, we need a result that there are perturbations that makes $M(W, S, P) \rightarrow G$ a family of manifolds, which once again boils down to the regularity of Fredholm maps.

Proposition 2.27. *There exists (secondary) perturbations such that the perturbed moduli space consists of regular solutions. Thus $M(W, S, P) \rightarrow G$ is a map with smooth fibers. Furthermore, if G is a manifold with corners, stratified by the dimension, there exists perturbation such that $M(W, S, P)$ is also a manifold with corners, with $M(W, S, P) \rightarrow G$ having smooth fibers when restricts to each strata.*

We want to compactify $M(W, S, P)$, in particular its one dimensional part. In another words, how families of ASD solutions (with varying metric) can degenerate. To do this, we want to introduce broken metric:

Definition 2.28. Given Y_c intersecting S transversly. A broken metric is a metric in $\text{int } W \setminus Y_c$ such that around Y_c , with normal coordinate r_c , it looks like

$$(2.29) \quad g = (dr_c/r_c)^2 + \tilde{g}_{Y_c}$$

where \tilde{g}_{Y_c} is a orbifold metric on (Y_c, L_c) .

Fix β_1 and β_0 on the cylindrical ends, we can define a cut path over a broken metric:

Definition 2.30. A cut path from β_1 to β_0 is a continuous connection A on P , smooth in $\text{int } W \setminus Y_c$, and its restriction on the ends is β_1 and β_0 . A cut trajectory is a cut path whose restriction to $\text{int } W \setminus Y_c$ is a solution to the perturbed ASD solution.

⁸there are subtleties with monopole charges that we are ignoring

⁹one can consider a family of bordisms, though this is not necessary for our purpose.

Now we describe a standard way a family of Riemannian metric can deform to a broken one. Fix \tilde{g}_0 on W , with a collar neighborhood of Y_c where the metric is a product $dr^2 + \tilde{g}_{Y_c}$. Let f_s be a family of functions given by

$$(2.31) \quad \frac{1 + 1/s^2}{r^2 + 1/s^2}$$

for $r \in [-1, 1]$ and 1 otherwise. Then we get a family of modified metric over $s \in [0, \infty]$:

$$(2.32) \quad f_s(r)dr^2 + \tilde{g}_{Y_c}$$

In particular, when $s = \infty$, it is broken along Y_c^i .

Moregenerally, if $Y_c = \sqcup_{i=0}^N Y_c^i$, then we can break it along each component, and get a broken metrics parametrized by $[0, \infty]^N$.

Definition 2.33. Fix Y_c with n components, A model family of singular metrics on (W, S) with Y_c is a family parametrized by $[0, \infty]^N \times G_1$, such that for any $a \in G_1$, the family varying in $[0, \infty]^N \times a$ is equivalent to the broken family described above.

We will be working with families of metrics that degenerates like the model family at the boundary:

Definition 2.34. A family of broken metrics is a family of metrics over manifold with corners G , such that for every codimension n facet, there is a cut Y_c with exactly n components, such that in the neighborhood of that point the family is equal to a neighborhood of $\{\infty\}^n \times G_1$ for some model family for the cut Y_c .

Now to compactify this, we need to know what other way can the ASD instanton slide off. Let us summarize the relevant result here:

Proposition 2.35. *Given a family of broken metrics, (after choosing suitable perturbation), we have parametrized moduli space $M_{int G}(\beta_1, \beta_0)$ over $int G$. This is a completion $M_{z,G}^+(\beta_1, \beta_0)$, with the following codimensional 1 strata:*

- (1) A cut trajectory along connected Y_c .
- (2) Strata from trajectory sliding off the incoming end, having the form

$$(2.36) \quad M(\beta_1, \alpha_1)_0 \times M_G(\alpha_1, \beta_0)_0$$

where α_1 is a critical point on Y_1 .

- (3) Sliding off the outgoing end, having the form:

$$(2.37) \quad M_G(\beta_1, \alpha_0) \times M(\alpha_0, \beta_0)$$

where α_0 is a critical point on Y_0 .

Moreover, $M_G^+(\beta_1, \alpha_0)_d$ is compact when $d < 4$.

Remark 2.38. In general $M_G^+(\beta_1, \alpha_0)$ is not compact, since the limit can bubble off instantons and monopoles. However, those changes the dimension of the moduli space by multiples of 4.

Remark 2.39. In order to define the sign counts, we need to give orientation to these moduli spaces and show compatibility at the boundaries. See [3].

3. KNOT INSTANTON HOMOLOGY

3.1. Instanton homologies for singular instantons. Now we can define instanton homology for knots:

Construction 3.1. We start by defining the chain complex. Fix (Y, L) and P a singular bundle data on (Y, L) with non-integral condition. In addition, let g be an orbifold metric on Y . Let \mathfrak{C} be the finite set of critical points for the (perturb) Chern-Simons functional. Let $C^*(Y, L, P) = \bigoplus_{\beta \in \mathfrak{C}} \mathbb{Z}\beta$, where we have a generator for each critical point $\beta \in \mathfrak{C}$.

Now to define the chain complex: fix two critical points β_0, β_1 , then let M_{β_0, β_1} be the moduli space of (perturbed) ASD instantons on the cylinder $I \times (Y, L)$ with the product orbifold metric. There is a \mathbb{R} translation action on M_{β_1, β_0} , which is free away from the constant solution. Let $\tilde{M}(\beta_0, \beta_1)$ be the quotient of such action, and throw away the constant one. Then the β_1 coefficient of $d(\beta_0)$ is the sign count of the zero-dimensional instantons $\tilde{M}(\beta_0, \beta_1)_0$ (up to suitable signs).

Proposition 3.2. $C^*(Y, L, P)$ is a chain complex, that is, $d^2 = 0$.

Proof. Given $\beta_2, \beta_0 \in \mathfrak{C}$, we will show that β_2 component of $2d^2\beta_0$ is 0. This follows from Proposition 2.35: $2d^2$ counts the sign count of $\sqcup_{\beta_1 \in \mathfrak{C}} \tilde{M}(\beta_0, \beta_1)_0 \times \tilde{M}(\beta_1, \beta_0)_0$. By Proposition 2.35, with the family of metric being $*$, this precisely counts the boundaries of 1 dimensional ASD instantons space M_{β_2, β_0} , by sliding of to the left or sliding of to the right. \square

Furthermore, it is independent of auxiliary data:

Proposition 3.3. The instanton homology is independent of the auxiliary data, namely the orbifold metric and the perturbations.

Definition 3.4. We denote the homology of $C^*(Y, L, P)$ as $I^*(Y, L, P)$. We will often leave P to be implicit.

3.2. Bordisms and functorialities. In this section we show that the instanton homology is compatible with bordism.

Construction 3.5. Given a bordism (W, S) with singular instanton P satisfying non-integral condition, we will define a chain map $f_W : C^*(Y_1, L_1) \rightarrow C^*(Y_0, L_0)$.

Once again, we need to define the β_0 coefficient f_W of β_1 , for $\beta_i \in \mathfrak{C}_i$. Let $M(\beta_1, \beta_0)$ be the (perturbed) moduli space of ASD solutions, then the coefficient is the sign count of zero dimensional moduli space $M(\beta_1, \beta_0)_0$.

Remark 3.6. Note that here there is no \mathbb{R} action we are quotienting by, as oppose to the chain complex differential.

Just as before, we have the following:

Proposition 3.7. (1) The map above is a map of chain complex, that is, $fd + df = 0$.

(2) The map f on homology is independent of the auxiliary data.

Proof. Let us prove the first part. By Proposition 2.35, we see that $fd + df$ is counting the boundary of $M^+(\beta_1, \beta_0)_1$, which is a compact 1-manifold with boundary. \square

Warning 3.8. There is a sign ambiguity in this construction that we have not mentioned. Namely, the chain complex is defined up to ± 1 . See [3] for detail.

Lastly, we want an homology theory without mentioning “with a singular bundle data”. We can construct (an isomorphism class) of singular bundle data by specifying the Poincare dual of $w_2(P)$.

Definition 3.9. A WINK triple is (Y, L, ω) consisting of:

(1) Y a closed, oriented, connected 3-manifold.

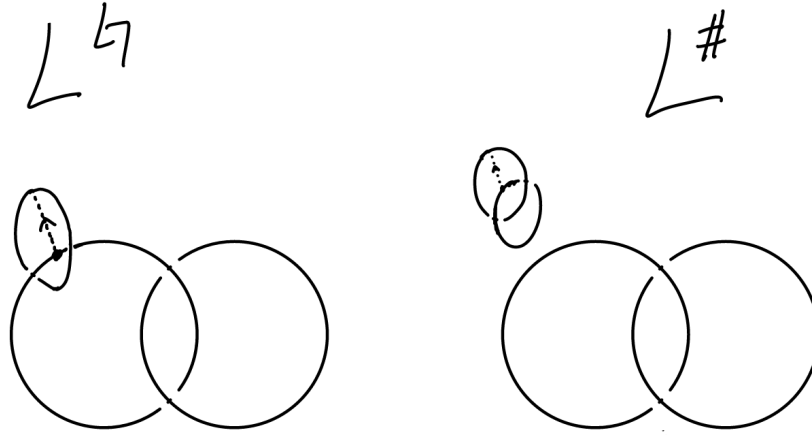

FIGURE 4. On the left we have L^\sharp for the Hopf link, on the right we have L^\sharp for the Hopf link.

- (2) L an unoriented link in Y .
- (3) ω an embedded 1-manifold with $\omega \cap L = \partial\omega$, meeting L normally at endpoints.

Moreover, there is a natural notion of bordisms between them.

Definition 3.10. A bordism between (Y_1, L_1, ω_1) to (Y_2, L_2, ω_2) is an isomorphism class of triples:

- (1) (W, S) a bordism of pairs, with W is an oriented bordism.
- (2) $\omega \subset W$ a 2-manifold with corners, with boundary $\omega_1 \cup \omega_0$ and some arcs in S , which is normal to S . The intersection $\omega_i \cap S$ has finitely many points where the intersection is transverse.

Let $WINK$ be the category of WINK triples and bordisms. Then

Proposition 3.11. *Singular instanton homology defines a functor $I^\omega : WINK \rightarrow P-GROUP$ where $P-GROUP$ is the category of abelian groups with projective homomorphisms, that is, homomorphisms up to ± 1 . We will denote $I^\omega(Y, L)$ the instanton homology associated to (Y, L, ω) .*

3.3. Reduced and unreduced knot instanton homology. Here we introduce two more variants for links, with varying data.

Given link $L \subset Y$ with a basepoint $x \in L$ and a normal vector v to L at x . Let L' be the unit circle at the boundary of a standard disk, and ω be a radius with tangent vector v . This defines a new link:

$$(3.12) \quad L^\sharp = L \sqcup L'$$

See Figure 4 for an example.

Definition 3.13. The reduced instanton homology of (Y, L, x, v) is

$$(3.14) \quad I^\sharp(Y, L, x, v) = I^\omega(Y, L^\sharp)$$

This defines a functor from a category with objects (Y, L, x, v) and bordisms between them to P-GROUPS.

Remark 3.15. The isomorphism class of $I^\natural(Y, L, x, v)$ only depends on (Y, L) and a marked component.

Proposition 3.16. *For the unknot U , $I^\natural(S^3, U) = \mathbb{Z}$.*

Proof. We are computing I^ω of the Hopf link $H = U^\natural$ with an arc joining the components. The set of critical points of the unperturbed Chern-Simons function is a point. Therefore the chain complex is \mathbb{Z} . \square

We want an invariant of just links $L \subset Y$. To do so, we can just add a new unknot U with a basepoint on U . Thus

$$(3.17) \quad L^\natural = (L \sqcup U)^\natural$$

which is the disjoint union of L and a Hopf link H away from L , and ω joins the two components of the Hopf link. See Figure 4.

Definition 3.18. The unreduced instanton homology of L is $I^\natural(Y, L) := I^\natural(Y, L \sqcup U, x, v)$.

Corollary 3.19. $I^\natural(\emptyset) = \mathbb{Z}$.

Proof. $\emptyset^\natural = U^\natural = H$, where U is the unknot and H is the Hopf link. The result follows from Proposition 3.16. \square

With some additional detail, we can get rid of the ± 1 ambiguity:

Proposition 3.20. *There is a consistent choice $I^\natural : LINKS \rightarrow Ab$, where $LINKS$ is the category of oriented links in \mathbb{R}^3 and bordisms thereof.*

Lastly, let's discuss the grading on the Instanton homology. Note that given two critical points β_1, β_0 , there is a $\mathbb{Z}/4$ grading rather than a \mathbb{Z} grading, since adding instantons and monopoles changes a multiple of 4 to the relative grading.

Therefore we have a relative $\mathbb{Z}/4$ grading for I^ω . But we can define an absolute $\mathbb{Z}/4$ grading for I^\natural and I^\natural . Let us record the one for \natural :

Proposition 3.21. (1) *There is an absolute $\mathbb{Z}/4$ grading on I^\natural such that the generator of $I^\natural(\emptyset)$ is in degree 0.*

(2) *For any bordism (W, S) from $(Y_1, L_1) \rightarrow (Y_0, L_0)$, the grading shift is*

$$(3.22) \quad -\chi(S) + b_0(L_0) - b_0(L_1) - \frac{3}{2}(\chi(W) + \sigma(W)) + \frac{1}{2}(b^1(Y_0) - b^1(Y_1))$$

4. SKEIN LONG EXACT SEQUENCE

4.1. Smoothings and bordisms. Let us revisit the notion of smoothing, and put them in a more symmetric matter: Let $L \subset Y$ be a link and B^3 a ball in Y such that L intersect it transversly at the four vertex of the tetrahedron (see Figure 5). When projected to the plane, the three pictures become the crossing, 1 resolution, and 0 resolution. Let us call them 2, 1, and 0 smoothings. More generally, for $v \in \mathbb{Z}$, the v smoothing is the $v \bmod 3$ smoothing. Let L_v be the corresponding link as before. There are bordisms $S_{v+1, v}$ between them, once again generalizing the $S_{2,1}$ case (see Figure 5)

It will be crucial for us to understand the composite of the bordisms. By symmetry, it is suffice to consider $S = S_{1,0} \circ S_{2,1}$. Recall that we have another bordism $S_{0,2}^{op}$ where we equipped $S_{2,0}$ with the opposite orientation, where $S_{0,2}$ is one of the standard bordism between those smoothings.

Proposition 4.1. *S , a bordism from L_0 to L_2 in $I \times Y$ has the form*

$$(4.2) \quad (I \times Y, S_{0,2}^{op}) \# (S^4, \mathbb{R}P^2),$$

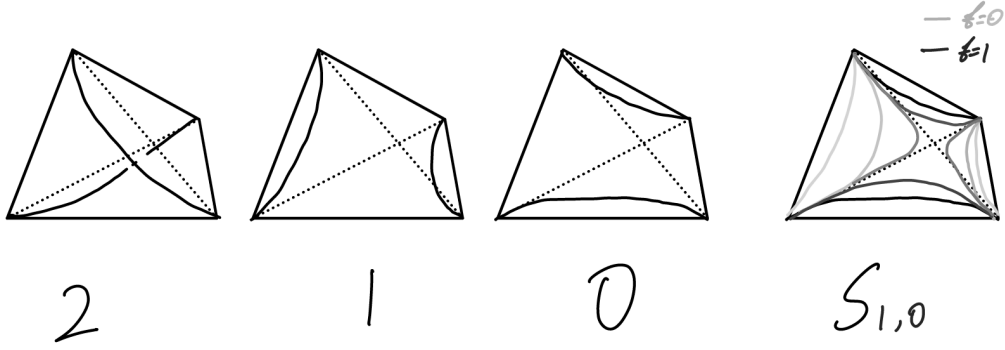

FIGURE 5. The 3 different smoothings and the bordism $S_{1,0}$.

where $\mathbb{R}P^2$ is embedded in S^4 with self-intersection $+2$. Equivalently, away from a ball B^4 , S is isomorphic to $S_{0,2}^{op}$. Furthermore, the intersection between S and the ball B^4 is an Mobius and, with the boundary being an unknot on $S^3 = \partial B^4$.

Proof. There is a constant arc γ in the projection of $S_{1,2}$ and $S_{2,1}$ into the B^4 . Away from this arc δ , really $\gamma \times I$, formally, the neighborhood of $\gamma \times I$, $S_{2,0}$ looks just like $S_{0,2}^{op}$. However, the normal neighborhood of $\gamma \times I$ intersect $S_{2,0}$ to form a Mobius band. See Figure 6. \square

4.2. The Skein long exact sequence. In this section we will show the following:

Theorem 4.3. *The bordism $S_{v+1,v}$ induces maps*

$$(4.4) \quad \cdots \rightarrow I^\omega(L_v) \rightarrow I^\omega(L_{v-1}) \rightarrow I^\omega(L_{v-2}) \rightarrow \cdots .$$

This is a long exact sequence.

Let us record a form of this that we will generalize in Section 5.1: Given the map $f_{v-1,v-2}$, we can construc the cone chain complex $C^*(v-1, v-2)$. To be explicit the chain complex of $C^*(v-1, v-2)$ is $C^*(v-1) \oplus C^{*-1}(v-2)$ with the differential being

$$(4.5) \quad d = \begin{pmatrix} -d_{v-1} & 0 \\ f_{v-1,v-2} & d_{v-2} \end{pmatrix}$$

where d_{v-i} is the differential for the instanton chain complex.

Corollary 4.6. *We have a chain map:*

$$(4.7) \quad C^*(L_v) \rightarrow C^*(v-1, v-2)$$

that induces an isomorphism on homology.

We will use the following algebraic lemma to proof this:

Proposition 4.8. *Suppose for each i we have chain complex (C_i, d_i) and chain maps: $f_i : C_i \rightarrow C_{i-1}$. If we have a chain homotopy j_i for the composite $f_{i-1} \circ f_i$:*

$$(4.9) \quad d_{i-1}j_i + j_i d_i + f_{i-1}f_i = 0$$

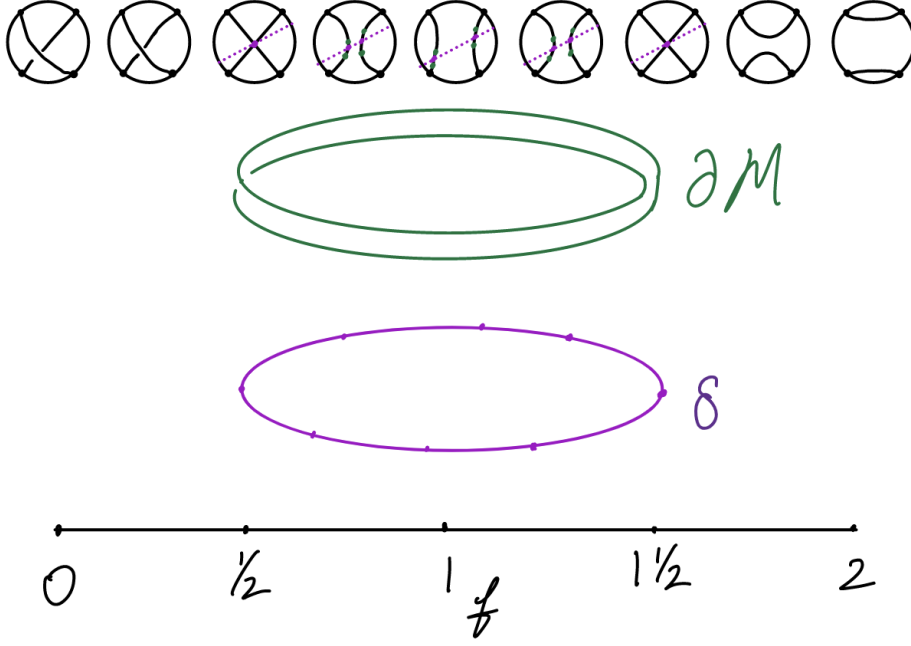

FIGURE 6. On top we see a 2D projection of the composite S , where we parametrize time on the bottom. For $t \in [0, 1]$ it is $S_{2,1}$, from $t \in [1, 2]$ it is $S_{1,0}$. The purple line is γ and the purple points are the intersection of $I \times \delta$ and S . We see that the intersection forms a circle δ . Furthermore, the green dots are the boundaries of a tubular neighborhood of δ in \S . We see that it is an unknot and the tubular neighborhood is a Mobius strip.

for all i . Furthermore, suppose for all i , the map

$$(4.10) \quad j_{i-1}f_i + f_{i-2}j_i : C_i \rightarrow C_{i-3}$$

is an isomorphism on homology. Then this induce a long exact sequence on homology. Furthermore, the map

$$(4.11) \quad \Phi : C_i \rightarrow \text{Cone}(f_i)$$

$$(4.12) \quad s \mapsto (f_i s, j_i s)$$

induces isomorphism on homology.

Proof of Theorem 4.3. Using the proposition above, it is suffice to construct J with those properties. For sake of simplicity, we will focus on showing the first equation

$$(4.13) \quad d_{i-1}J_i + J_i d_i + f_{i-1}f_i = 0.$$

By symmetry, it is suffice to construct $J_2 : C_2 \rightarrow C_0$ satisfying above.

To construct J_2 , we need to consider the composite bordism $S = S_{1,0} \circ S_{2,1}$. By Proposition 4.1, the composite bordism is a connect sum $(I \times Y, S_{0,2}^{op}) \# (S^4, \mathbb{R}P^2)$. Now we use the neck-stretching argument to get a one parameter family of metrics on (W, S) : fix a parameter τ , for $\tau \geq 0$, consider the metric on S such that the critial point for $S_{2,1}$ and $S_{1,0}$ differ by $\tau + 1$. Note that $S_{1,0}$ always comes after $S_{2,1}$.

This defines a family of metric over $[0, \infty]$, where it is a broken metric at ∞ . However, we want to extend it to $[-\infty, \infty]$: for $\tau \leq 0$, we sketch the neck of the connect sum. At $-\infty$, the metric is broken at the neck S^3 . Altogether we form a space $G_{2,0} = [-\infty, \infty]$ of broken metrics.

Now we get a parametrized moduli space $M(\beta, \alpha) \rightarrow G_{2,0}$ for $\beta \in \mathfrak{C}_2, \alpha \in \mathfrak{C}_0$. Now just as before, we define J by having its β coefficient of $J(\alpha)$ to be the sign count of $M(\beta, \alpha)_0$.

To show Equation (4.13), we need to understand the one dimensional stratum of the compactification $M^+(\beta, \alpha)$. By Proposition 2.35, we see that the boundary of $M^+(\beta, \alpha)_1$ are the following:

- (1) The instanton slides off to either end, which contributes $d_{i-1}J_i + J_id_i$.
- (2) The metric gets broken in the middle L_v , which contributes $f_{i-1}f_i$.
- (3) The metric gets broken at the neck S^3 .

Therefore it remains to argue why there is no contribution from the third type. Note that the pair (S^3, S^1) fails the non-integral condition. Furthermore, since all solutions on $(S^4, \mathbb{R}P^2)$ are irreducible, and the unique critical point for (S^3, S^1) is reducible, there are no contributions from the cut.

It remains to show Equation (4.10), which follows from a similar construction by examining the triple bordism $S = S_{1,0} \circ S_{2,1} \circ S_{0,2}$. See [3] for the proof. \square

5. CUBE CONSTRUCTION

5.1. Knot instanton homology of cubes. Given a link $L \subset Y = S^3$. Suppose there are N disjoint balls $B^3 \subset S^3$ such that the intersection $L \subset B^3$ intersect at four points of a tetrahedron. For $v \in (\mathbb{Z}/3)^N$, let L_v be the link with the v_i smoothing with the i -th ball.

Fix u, v such that for each i , $v_i - u_i = 0$ or 1 , we would like to construct a total chain complex $C^*(u, v)$. We begin with a family of metric. Let J denote the subset of balls where $v_j = u_j + 1$. Then there is a $G_{v,u} = \mathbb{R}^J$ family of bordisms from L_v to L_u : for each $\tau_i \in \mathbb{R}^J$, we have a bordism it is the constant bordism outside of the balls, but for ball $j \in J$ it is the S_{u_i, v_i} bordism where the critical point appears at time τ_j . There is a canonical diffeomorphism between these bordism, only the metric is different. Therefore we get a family of metric. See Figure 7.

There is a free \mathbb{R} action by translating all τ_i , let $\tilde{G}_{v,u}$ be the quotient, equivalently, it is the subspace of $\sum_i \tau_i = 0$.

Next, there is a natural compactification \tilde{G}_{uv} , by taking some difference $\tau_i - \tau_j$ goes to ∞ . For each simplex $\sigma = \{u = v_1 < v_2 \dots < v_n = v\}$, let

$$(5.1) \quad G_\sigma = \prod G_{v_2, v_1} \times \dots \times G_{v_n, v_{n-1}}.$$

Lemma 5.2. *There is a compactification of \tilde{G}_{uv} , called \tilde{G}_{uv}^+ , such that*

$$(5.3) \quad \tilde{G}_{uv}^+ = \cup_\sigma G_\sigma.$$

Furthermore, this is a family of broken metrics, where the cuts are between differences $\tau_i - \tau_j$ that goes to ∞ .

Example 5.4. $N = 1, u = v$, then $\tilde{G} = *$. There is no compactification.

Example 5.5. Take $N = 2, v = u + 1 = (u_1 + 1, u_2 + 1)$. Then $G_{uv} \simeq \mathbb{R}$ is parametrizing the difference in time between the critical points in the two balls, and \tilde{G}_{uv}^+ adds two points at infinity, for the case that $\tau_1 - \tau_2 = \infty$ and $\tau_1 - \tau_2 = -\infty$. The cuts intersects the bordisms at L_{u_1+1, u_2} and L_{u_1, u_2+1} .

Now we compactify the moduli space. Just as before, fix $\beta \in \mathfrak{C}_v, \alpha \in \mathfrak{C}_u$, then we get a parametrized family of (perturbed) ASD connection:

$$(5.6) \quad M(\beta, \alpha) \rightarrow G_{uv}.$$

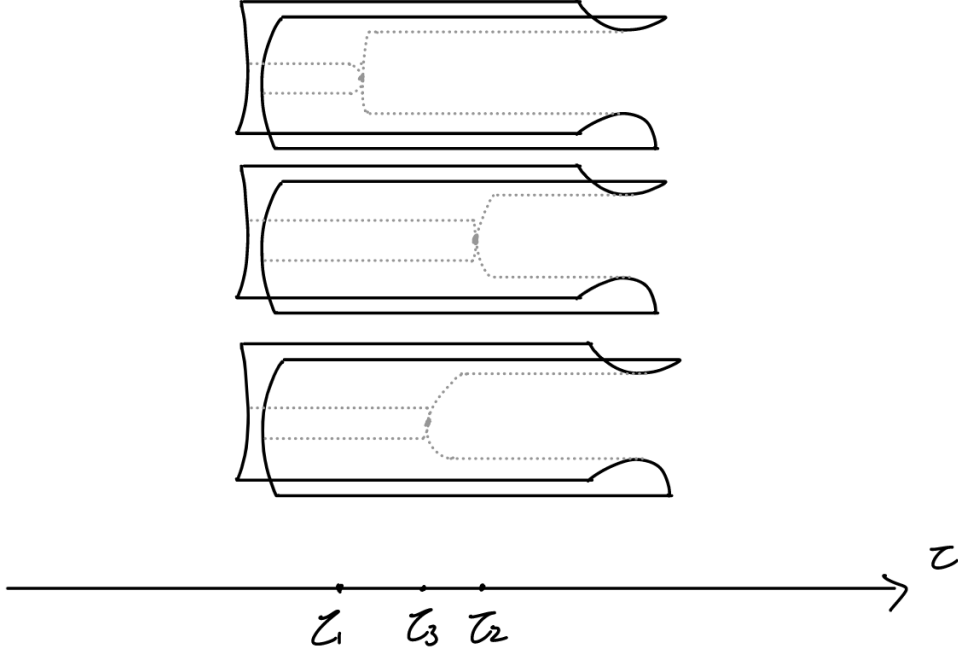

FIGURE 7. An example with $N = 3$, $v = (1, 1, 1)$, and $u = (0, 0, 0)$.

There is a free \mathbb{R} action on $M(\beta, \alpha)$, when $u \neq v$, which we quotient to get

$$(5.7) \quad \tilde{M}(\beta, \alpha) \rightarrow \tilde{G}_{uv}$$

As before, in the case that $u = v$, we throw away the constant part before quotienting. Let $\tilde{M}(\beta, \alpha)_d$ be the d -dimensional part. Now we want to compactify $\tilde{M}(\beta, \alpha)$. There are two phenonemom for the limits at infinity:

- (1) The metric gets broken in the middle.
- (2) The connection slides off to the end or the slices.

To cover both of these cases, let's consider degenerate simplicies $\sigma = (u = v_1 \leq v_2 \leq \dots \leq v_n = v)$, where we allow repeats. Then given a sequence $\beta_\sigma = (\beta = \beta_1 \in \mathfrak{C}(v_1), \beta_2 \in \mathfrak{C}(v_2), \dots, \beta_n = \alpha \in \mathfrak{C}(v_n))$, let

$$(5.8) \quad \tilde{M}_\sigma(\beta) = \tilde{M}(\beta_2, \beta) \times \dots \times \tilde{M}(\alpha, \beta_{n-1})$$

There is a natural map

$$(5.9) \quad \tilde{M}_\sigma(\beta) \rightarrow \tilde{G}_{\sigma'}$$

where σ' is obtained by removing repeats from σ . By Proposition 2.35, we get

Proposition 5.10. *There is a compactification $\tilde{M}(\beta, \alpha), \tilde{M}^+(\beta, \alpha) \rightarrow \tilde{G}^+(\beta, \alpha)$, which is a union*

$$(5.11) \quad \tilde{M}^+(\beta, \alpha) = \cup_\sigma \cup_{\beta_\sigma} \tilde{M}_\sigma(\beta_\sigma)$$

Moreover, for any β, α where \tilde{M}_1^+ is non-empty, the completion $\tilde{M}^+(\beta, \alpha)$ is a compact 1-manifold with boundary, with the boundary being zero dimension products of the form

$$(5.12) \quad \tilde{M}(\beta, \beta_1)_0 \times \tilde{M}(\beta_1, \alpha)_0$$

with $\beta_1 \in \mathfrak{C}_{v_1}$, and $v \leq v_1 \leq u$ a degenerate simplex. Furthermore, we can assign compatible orientation to $\tilde{M}^+(\beta, \alpha)$ and its corners.

Having this, let $f_{v,u}(\beta, \alpha)$ be signed count of $\tilde{M}_0(\beta, \alpha)$. This defines $f_{v,u} : \bigoplus_{\beta \in \mathfrak{C}_v} \mathbf{Z}\beta \rightarrow \bigoplus_{\alpha \in \mathfrak{C}_u} \mathbf{Z}\alpha$.

Let $C^*(v, u)$ be the chain complex defined as follows: the group is $\bigoplus_{v \geq v_1 \geq u} C_{v_1}^* = \bigoplus_{v \geq v_1 \geq u} \bigoplus_{\beta' \in \mathfrak{C}_{v_1}} \mathbf{Z}\beta'$. The differential is

$$(5.13) \quad F = \bigoplus_{v \geq v_1 \geq v_2 \geq u} f_{v_1, v_2}$$

By Proposition 5.10, we have the following:

Corollary 5.14. $C^*(v, u)$ is a chain complex, that is, $F^2 = 0$.

Example 5.15. When $v = u$, then this is simply the instanton chain complex $C^\omega(v)$.

Example 5.16. When v and u only differ in one component, then $C^*(v, u)$ is the cone of f_{uv} constructed in the last section.

Remark 5.17. Say v and u differ in n components, then we are really looking for $(-n + 1)$ -dimensional instanton on the bordism $S_{u,v}$. This is because we are looking for dimension 0 instanton over a \mathbb{R}^{N-1} family.

5.2. Generalization of the Skein long exact sequence. In this section we prove the generalization of Corollary 4.6:

Theorem 5.18. Fix L with N balls as before. Pick v, u with $v_i - u_i = 0$ or 1. Let $w = 2v - u = 2(v + u)$. Then there is a map $C^*(w) \rightarrow C^*(v, u)$ that induces an equivalence on homology.

Proof. We will do this by induction. Note that the $N = 1$ case is Corollary 4.6. It is sufficient to consider the case $w = (2, \dots, 2)$, $v = (1, 1, \dots, 1)$, $u = (0, \dots, 0)$. Let $C_i^* = \bigoplus_{v' \in \{0,1\}^{N-1}} (C_{v',i}^*)$, basically we fixed the last coordinate. Then

$$(5.19) \quad C^*(u, v) = C_1^* \oplus C_0^*$$

and F is of the form

$$(5.20) \quad F = \begin{pmatrix} F_{11} & 0 \\ F_{10} & F_{00} \end{pmatrix}.$$

Similarly, we have the chain complex C_2^* where we fix the last coordinate. By induction, we have a chain map $C^*(w) \rightarrow C_2^*$ that induces isomorphism on homology. Therefore it suffices to show that

Theorem 5.21. There is a chain map

$$(5.22) \quad C_2^* \rightarrow C^*(v, u)$$

that induces an isomorphism on homology. □

This is the same form as Corollary 4.6, and can be proven in the same way.

6. KHOVANOV TO INSTANTON HOMOLOGY

6.1. Knot instanton spectral sequence. In this section we develop the spectral sequence and show that it recovers the Khovanov homology.

Using the setup from last section: we have a link L with N balls where they are of smoothing 2 (the crossing one), together with ω defined away from the balls.

Recall that we have a chain complex $C_{(1,1,\dots,1),(0,0,\dots,0)}^*$ that computes the instanton homology $I^\omega(L)$. Recall that the differential is naturally lower triangular. This means that there is a natural filtration on $C_{(1,1,\dots,1),(0,0,\dots,0)}^*$ given by the sum of the coordinates, therefore:

Proposition 6.1. *There is a spectral sequence converging to $I^\omega(Y, L)$, whose E_1 groups are the Instanton homology $\bigoplus_{v' \in [0,1]^N} I_*^\omega(Y, L_{v'})$. Its E_1 differential are the sums of $f_{v', u'}$ on instanton homology, where v' and u' differ only in the j -th component, where $f_{v', u'}$ is the the $S_{v'_j, u'_j}$ bordism in the ball that they differ.*

Proof. The E_1 groups are the homology groups of the d_0 differential. Recall that the d_0 differential are the diagonal terms. Furthermore, the one lower diagonal terms on homology gives the E_1 differential. The result follows from the fact that the diagonal terms are the instanton differentials, and the one lower diagonal terms are precisely the chain complex maps induced by $S_{v'_j, u'_j}$. \square

6.2. Khovanov is the E2 page. Now we connect Khovanov and knot instanton homology: given a link diagram L' , with the associated link $L \subset \mathbb{R}^3$. We put a ball around each crossing. Furthermore, we can attach a Hopf link at ∞ , as in the sharp construction. Therefore we get a chain complex $C^\sharp((1, \dots, 1), (0, \dots, 0))$ that computes $I^\sharp(L)$.

Theorem 6.2. *The $\mathbb{Z}/4$ -graded reduction of the Khovanov homology $Kh(L)$ is the E_2 page of the the instanton spectral sequence for $I^\sharp(L)$.*

Remark 6.3. The $\mathbb{Z}/4$ relates to the double grading by the following, let q and h be the q -grading and the homological grading, then the associated $\mathbf{Z}/4$ grading is $q - h - b_0(L)$.

By Proposition 6.1, we need to show the following:

- (1) The Instanton homology for unlinks of n components $I^\sharp(U_n)$ can be identified $V^{\otimes n}$.
- (2) The pair of pants bordisms on instanton homology induces μ and Δ on instanton homology, where μ and Δ are defined in Section 1.2.

We will start with the first part:

6.2.1. Unlinks. Let U_n be an unlinks in \mathbb{R}^3 with n components, lying all on the (x, y) plane, diameter $1/2$ and centered on the first n integer lattice on the x -axis. For J a subset of U_n , let U_J be the subset of unlinks with those components. By Corollary 3.19, $I^\sharp(U_0) \simeq \mathbb{Z}$ in degree $0 \bmod 4$, and we fix a generator $u_0 \in \mathbb{Z}$.

Proposition 6.4. *$I^\sharp(U_1) \simeq \mathbb{Z} \oplus \mathbb{Z}$ with generators in degree 0 and $-2 \bmod 4$.*

Proof. We use the Skein long exact sequence to a Hopf link H with a twist (see Figure 8). Smoothing it gives a long exact sequence between H and $H \sqcup U_1$, now the long exact sequence goes as

$$(6.5) \quad I^\sharp(U_0) \xrightarrow{a} I^\sharp(U_1) \xrightarrow{b} I^\sharp(U_0) \xrightarrow{c} I^\sharp(U_0)$$

with a, b degree -2 , and c degree 1 . Therefore $c = 0$ and $I^\sharp(U_1)$ is free of rank 2 with generators in 0 and -2 . \square

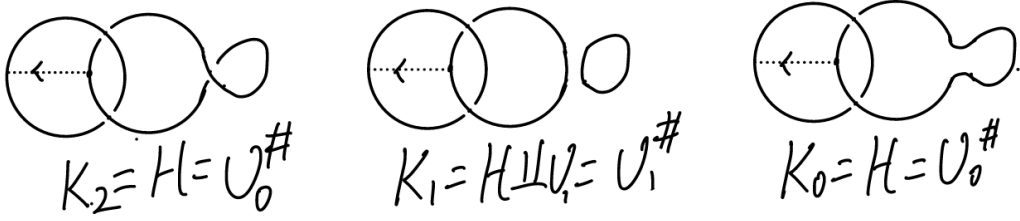
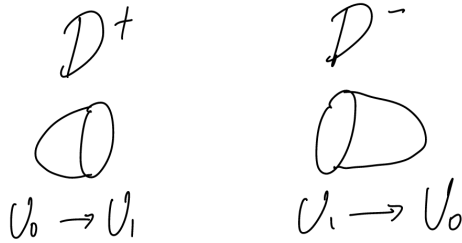

FIGURE 8. Given a Hopf link with a twist, we consider the 3 smoothings around the twists.

 FIGURE 9. D^+ and D^- bordisms.

To get an explicit description, let D be the standard disk in U_1 that bounds in the (x, y) plane. Let D^- be the oriented bordism from U_0 to U_1 by pushing D into $[0, 1] \times \mathbb{R}^3$ (see Figure 9), and D^+ the bordism from $U_1 \rightarrow U_0$ with opposite orientation. They give maps $I^\sharp(D^+) : I^\sharp(U_0) \rightarrow I^\sharp(U_1)$ and $I^\sharp(D^-) : I^\sharp(U_1) \rightarrow I^\sharp(U_0)$ of degree 0 and -2 .

Lemma 6.6. *There are generators v_+, v_- for $I^\sharp(U_1)$ in degree 0 and $-2 \bmod 4$, such that*

$$(6.7) \quad I^\sharp(D^+)(u) = v_+, I^\sharp(D^-)(v_-) = u.$$

Proof. For the first part, suffice to show that $I^\sharp(D^+) \circ b = id$ on $I^\sharp(U_0)$. It follows from the fact that the composite bordism is isomorphic to the product bordism. Similarly, $I^\sharp(D^-) \circ a$ is also the product bordism by the reverse diagram. \square

Repeating this argument, we get:

Corollary 6.8. *Let $A = \mathbb{Z}[v_+, v_-] \simeq \mathbb{Z}^2$, then we have an isomorphism of $\mathbb{Z}/4$ -graded abelian groups,*

$$(6.9) \quad \phi_n : A^{\otimes n} \rightarrow I^\sharp(U_n)$$

for all n , such that, let D_n^+ be the bordism from U_0 to U_n by standard disk, then

$$(6.10) \quad I^\sharp(D_n^+)(u_0) = \phi(v_+ \otimes \dots \otimes v_+)$$

similarly for D_n^- .

With a bit more work, one can show this for general unlinks:

Proposition 6.11. *Let U_n be an oriented n -component unlink U_n with components L_1, \dots, L_n , there is an isomorphism:*

$$(6.12) \quad \phi : A^{\otimes n} \rightarrow I^\sharp(U_n)$$

such that for any orientation-preserving isotopies U_n to U'_n , ϕ_U and $\phi_{U'}$ is compatible with $I^\sharp(S)$. Therefore if we enumerate U_n differently, this is equivalent to permuting the A 's in $A^{\otimes n}$.

Therefore it remains to compute what I does on unlinks.

6.2.2. *Pair of pants.* Let Π be the pair of pants from U_1 to U_2 , giving rise to $\mu : A \rightarrow A \otimes A$ of degree -2 . We also have Π' from $U_2 \rightarrow U_1$, giving rise to $\Delta : A \otimes A \rightarrow A$ of degree 0.

Lemma 6.13. *Under the isomorphism $\phi : V \rightarrow A$, mapping $x \mapsto v_-$ and $1 \mapsto v_+$, then μ and Δ agrees with the definition in Section 1.2.*

Proof. We start with $\mu(v_+)$: we know that

$$(6.14) \quad \mu(v_+) = \lambda_1(v_- \otimes v_+) + \lambda_2(v_+ \otimes v_-)$$

we precompose Π with a cap on U_1 , call this $D^+ \cup \Pi$, and we want $I^\sharp(D^+ \cup \Pi)(u_0)$. Now we attach a disk to the first disk of U_2 , this maps $v_- \otimes v_+ \rightarrow v_+$. This total bordism gives $\mathbb{Z} \rightarrow V$, taking u_0 to $\lambda_1 v_+$. However, this is just a disk D^+ , therefore $\lambda_1 = 1$. Similarly, $\lambda_2 = 1$.

Using a dual argument, we see that $\Delta(v_+ \otimes v_-) = \Delta(v_- \otimes v_+) = v_-$. With a bit more work, one can show the rest. \square

This completes the proof of Theorem 6.2.

REFERENCES

- [1] Mikhail Khovanov. A categorification of the jones polynomial. *Duke Mathematics Journal*, 2000. [1](#), [2](#), [3](#)
- [2] Peter Kronheimer and Tomasz Mrowka. Knots, sutures, and excision. *Journal of Differential Geometry*, 84(2):301–364, 2010. [1](#)
- [3] Peter B Kronheimer and Tomasz S Mrowka. Khovanov homology is an unknot-detector. *Publications mathématiques de l’IHÉS*, 113:97–208, 2011. [1](#), [9](#), [10](#), [15](#)
- [4] Peter Ozsváth and Zoltán Szabó. On the heegaard floer homology of branched double-covers. *Advances in Mathematics*, 194(1):1–33, 2005. [1](#)

1 OXFORD ST, CAMBRIDGE, MA 02139
 Email address: yuleonliu@math.harvard.edu